

TTK 175 S / TTK 355 S

EN

ORIGINAL INSTRUCTIONS
DEHUMIDIFIER



 TROTEC

Table of contents

Notes regarding the instructions 2

Safety 3

Information about the device..... 6

Transport and storage..... 6

Assembly and installation..... 8

Operation 11

Available accessories..... 13

Errors and faults..... 14

Maintenance 15

Technical annex..... 19

Disposal 24

Declaration of conformity 24

Notes regarding the instructions

Symbols



Danger

This symbol indicates dangers to the life and health of persons due to extremely flammable gas.



Danger

This symbol indicates dangers to life and health of persons due to the flammable substance R454C.



Warning of electrical voltage

This symbol indicates dangers to the life and health of persons due to electrical voltage.



Warning

This signal word indicates a hazard with an average risk level which, if not avoided, can result in serious injury or death.



Caution

This signal word indicates a hazard with a low risk level which, if not avoided, can result in minor or moderate injury.

Note

This signal word indicates important information (e.g. material damage), but does not indicate hazards.



Info

Information marked with this symbol helps you to carry out your tasks quickly and safely.



Follow the manual

Information marked with this symbol indicates that the instructions must be observed.

You can download the current version of the instructions and the EU declaration of conformity via the following link:

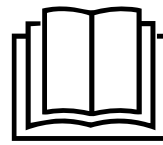

TTK 175 S



<https://hub.trotec.com/?id=39717>

TTK 355 S



<https://hub.trotec.com/?id=39718>

Safety

Read this manual carefully before starting or using the device. Always store the manual in the immediate vicinity of the device or its site of use!



Warning

Read all safety warnings and all instructions.

Failure to follow the warnings and instructions may result in electric shock, fire and / or serious injury.

Save all warnings and instructions for future reference.

This appliance can be used by children aged from 8 years and above and persons with reduced physical, sensory or mental capabilities or lack of experience and knowledge if they have been given supervision or instruction concerning use of the appliance in a safe way and understand the hazards involved.

Children shall not play with the appliance. Cleaning and user maintenance shall not be made by children without supervision.

- Do not use the device in potentially explosive rooms.
- Do not use the device in aggressive atmosphere.
- Set the device up in an upright and stable position.
- Let the device dry out after a wet clean. Do not operate it when wet or when in moist surroundings.
- Do not use the device with wet or damp hands.
- Do not expose the device to directly squirting water.
- Never insert any objects or limbs into the device and never use it as source of ignition.
- Do not cover or transport the device during operation.
- Do not sit on the device.
- This appliance is not a toy! Keep away from children and animals. Do not leave the device unattended during operation.
- Check accessories and connection parts for possible damage prior to every use of the device. Do not use any defective devices or device parts.
- Ensure that all electric cables outside of the device are protected from damage (e.g. caused by animals). Never use the device if electric cables or the power connection are damaged!
- The electrical connection must correspond to the specifications in chapter Technical data.
- Insert the mains plug into a properly secured mains socket.
- Observe the device's power input, cable length and intended use when selecting extensions to the power cable. Completely unroll extension cables. Avoid electrical overload.

- Before carrying out maintenance, care or repair work on the device, remove the mains plug from the mains socket. Hold onto the mains plug while doing so.
- Switch the device off and disconnect the power cable from the mains socket when the device is not in use.
- Do not under any circumstances use the device if you detect damages on the mains plug or power cable. If the supply cord is damaged, it must be replaced by the manufacturer, its service agent or similarly qualified persons in order to avoid a hazard. Defective power cables pose a serious health risk!
- When positioning the device, observe the minimum distances from walls and other objects as well as the storage and operating conditions specified in the Technical data chapter.
- Make sure that the air inlet and outlet are not obstructed.
- Make sure that the suction side is kept free of dirt and loose objects.
- Do not remove any safety signs, stickers or labels from the device. Keep all safety signs, stickers and labels in legible condition.
- Only transport the device in an upright position with an emptied condensation tank or drain hose.
- Discharge the collected condensate before transport and storage. Do not drink it. Health hazard!



Safety warnings for devices containing flammable refrigerants

- Only position the device in rooms where potentially leaking refrigerant cannot accumulate.
- Only position the device in rooms where there is no source of ignition (e.g. open flames, an active gas appliance or an electric heater).
- Please note that the refrigerant is odourless.
- Only install the device in compliance with the national installation regulations.
- Observe the national gas regulations.
- Only install, operate and store the device TTK 175 S / TTK 355 S in a room measuring more than 4 m².
- Store the device in a way that no mechanical damage can occur.
- Please note that the connected ducts must not contain any sources of ignition.
- R290 is a refrigerant that complies with European environmental regulations. No part of the cooling circuit may be perforated.
- R454C comes with a low GWP factor (Global Warning Potential) of 146 and an ODP (ozone depletion potential) of 0.

- Observe the maximum refrigerant capacity in the technical data.
- Do not drill through or burn.
- Do not use any means other than those recommended by the manufacturer for accelerating the defrosting process.
- Every person working with or at the refrigerant circuit must be able to provide a certificate of qualification issued by a body accredited by the industry, demonstrating their competence in the safe use of refrigerants based on a procedure well-known in the industry.
- Service work may only be carried out in accordance with the manufacturer's specifications. If maintenance and repair work require the support of additional persons, the person trained in handling flammable refrigerants shall continuously supervise the work carried out.
- Unventilated rooms, in which the device is installed, operated or stored, must be built in a way to ensure that potentially leaking refrigerant cannot accumulate. This serves to avoid fire or explosion hazards resulting from an ignition of the refrigerant by an electric furnace, cooking stove or another ignition source.
- The entire refrigerant circuit is a maintenance-free, hermetically sealed system and may only be maintained or repaired by specialist companies for cooling and air-conditioning or by Trotec.

Intended use

Only use the device for drying and dehumidifying room air, while adhering to and following the technical data.

Intended use comprises:

- dehumidifying and drying:
 - living rooms, bedrooms, bathrooms and basements
 - laundries, holiday homes, camper vans, boats
- maintaining the dryness of:
 - storage spaces, archives, laboratories, garages
 - bathrooms, wash rooms, changing rooms etc.

Improper use

- Do not place the device on wet or flooded ground.
- Do not place any objects, e.g. clothing, on the device.
- Do not use the device outdoors.
- Any unauthorised modifications, alterations or structural changes to the device are forbidden.
- Any operation other than as described in this manual is prohibited. Non-observance renders all claims for liability and guarantee null and void.

Personnel qualifications

People who use this device must:

- be aware of the dangers that occur when working with electric devices in damp areas.
- have read and understood the instructions, especially the Safety chapter.

Maintenance tasks which require the housing to be opened must only be carried out by specialist companies for cooling and air-conditioning or by Trotec.

Safety signs and labels on the device

Note

Do not remove any safety signs, stickers or labels from the device. Keep all safety signs, stickers and labels in legible condition.

The following safety signs and labels are attached to the device:

TTK 175 S

WARNING • WARNUNG • ATTENTION

- DE** Das Gerät muss in einem Raum mit einer Grundfläche größer als 4 m² aufgestellt, betrieben und gelagert werden.
- EN** Appliance shall be installed, operated and stored in a room with floor area larger than 4 m².
- FR** L'appareil doit être installé, utilisé et entreposé dans une pièce avec une surface supérieure à 4 m².



TTK 355 S

WARNING • WARNUNG • ATTENTION

- DE** Das Gerät muss in einem Raum mit einer Grundfläche größer als 4 m² aufgestellt, betrieben und gelagert werden.
- EN** Appliance shall be installed, operated and stored in a room with floor area larger than 4 m².
- FR** L'appareil doit être installé, utilisé et entreposé dans une pièce avec une surface supérieure à 4 m².



**Follow the manual**

This symbol indicates that the operating manual must be observed.

**Follow the repair manual**

Disposal, maintenance and repair work of the refrigerant circuit may only be carried out in accordance with the manufacturer's specifications and by persons having a certificate of qualification. A corresponding repair manual is available from the manufacturer upon request.

Residual risks**Danger****Natural refrigerant propane (R290)!**

H220 – Extremely flammable gas.

H280 – Contains gas under pressure; may explode if heated.

P210 – Keep away from heat, sparks, open flames and other ignition sources. No smoking.

P377 – Leaking gas fire: Do not extinguish, unless leak can be stopped safely.

P410+P403 – Protect from sunlight. Store in a well-ventilated place.

**Danger****Refrigerant R454C!**

H220 – Extremely flammable gas.

H280 – Contains gas under pressure; may explode if heated.

P210 – Keep away from heat, sparks, open flames and other ignition sources. No smoking.

P381 – Eliminate all ignition sources if safe to do so.

P403 – Store in a well-ventilated place.

**Warning of electrical voltage**

Work on the electrical components must only be carried out by an authorised specialist company!

**Warning of electrical voltage**

Before any work on the device, remove the mains plug from the mains socket!

Hold onto the mains plug while pulling the power cable out of the mains socket.

**Warning**

Dangers can occur at the device when it is used by untrained people in an unprofessional or improper way! Observe the personnel qualifications!

**Warning**

The device is not a toy and does not belong in the hands of children.

**Warning**

Risk of suffocation!

Do not leave the packaging lying around. Children may use it as a dangerous toy.

Note

Do not operate the device without an inserted air filter! Without the air filter, the inside of the device will be heavily contaminated. This could reduce the performance and result in damage to the device.

Behaviour in the event of an emergency

1. Switch off the device.
2. In an emergency, disconnect the device from the mains feed-in: Hold onto the mains plug while pulling the power cable out of the mains socket.
3. Do not reconnect a defective device to the mains.

Information about the device

Description of the device

The device uses the principle of condensation to automatically dehumidify rooms.

The fan sucks damp room air through the air inlet, the air filter, the evaporator and to the condenser located behind it. The air is cooled at the cold evaporator until it is below the dew point. Water vapour contained in the room air precipitates on the evaporator fins as condensation or rime. The dehumidified, cooled air is slightly warmed at the condenser and blown out again. The drier air thus conditioned mixes with the air in the room. The humidity in the room where the device is positioned is reduced as air constantly circulates through the device.

Depending on the air temperature and the relative humidity, the condensed water either drops continuously or only during the defrost phase through the integrated drain nozzle into the condensation tank below. It is fitted with a float to measure the filling level.

Optionally, the condensed water can be drained by attaching a hose at the condensation connection.

The device can reduce the relative humidity of a room to approx. 30 %.

The device has an operating element for operating and controlling the functions.

Device depiction

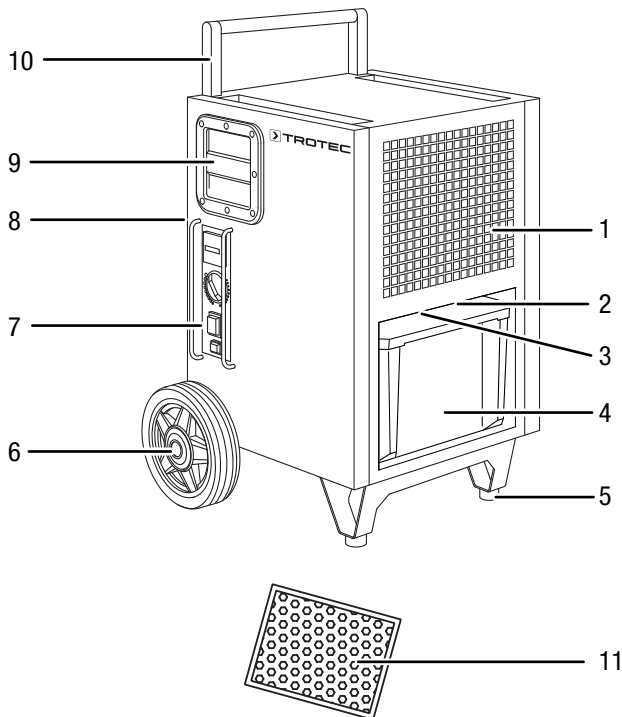

No.	Designation
1	Air inlet
2	Connection for optional condensate pump
3	Hose connector for condensation drain hose
4	Condensation tank
5	Feet
6	Wheels
7	Operating element
8	Air outlet
9	Carrying handle
10	Transport handle
11	Air filter

Transport and storage

Note

If you store or transport the device improperly, the device may be damaged. Note the information regarding transport and storage of the device.

Transport

To make the device easier to transport, it is fitted with a transport handle and two wheels.

Before transporting the device, observe the following:

- Switch off the device.
- Hold onto the mains plug while pulling the power cable out of the mains socket.
- Drain the remaining condensate from the device and the condensation drain hose (see chapter Maintenance).
- Do not use the power cable to drag the device.
- Do not incline the device by more than 45°, for otherwise the device could be damaged.
- Only wheel the device on a level and smooth surface.

Note

After unpacking the device, remove the two lower screws and adjust the transport handle. Afterwards, reinsert the screws. This only needs to be carried out the very first time that the device is unpacked.

Transport handle upon delivery

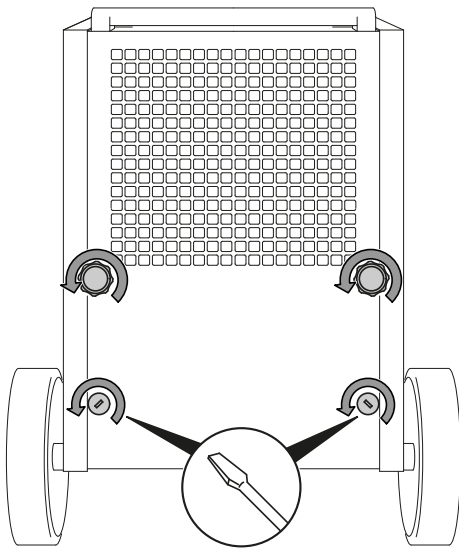

Transport handle in transport position

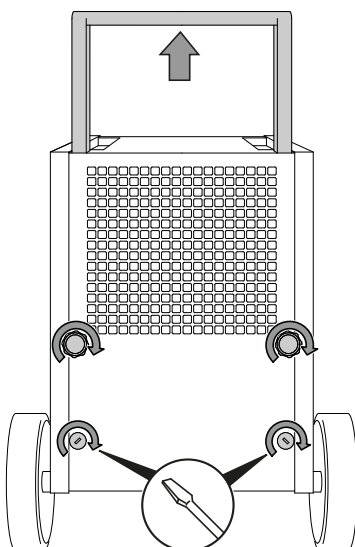
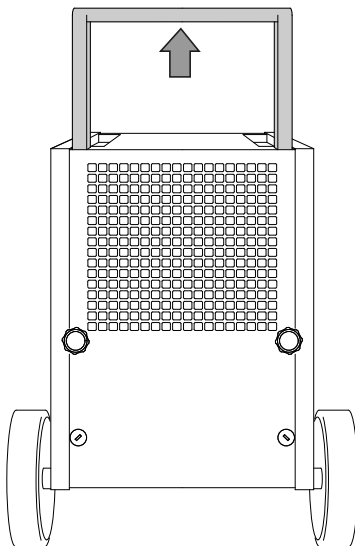

While transporting the device, observe the following:

- Hold the transport handle in both hands and tilt the device so that it can be rolled on its wheels.
- Move the device to the site where you want to use it.

Stacking

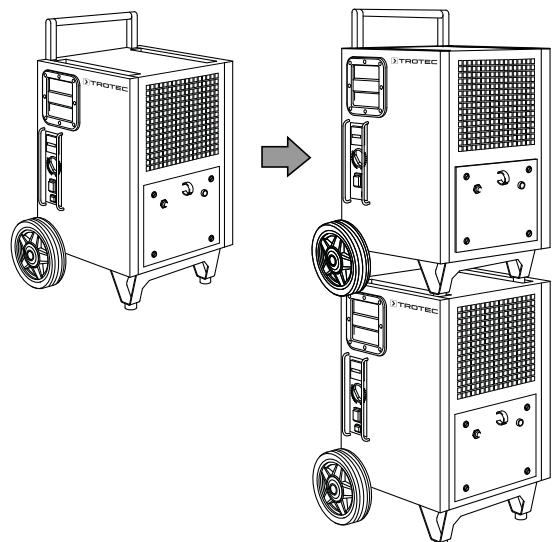
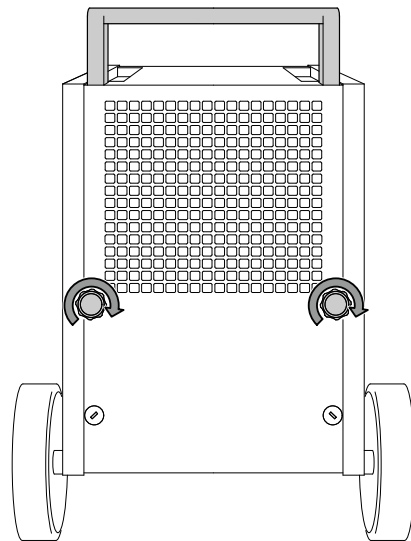
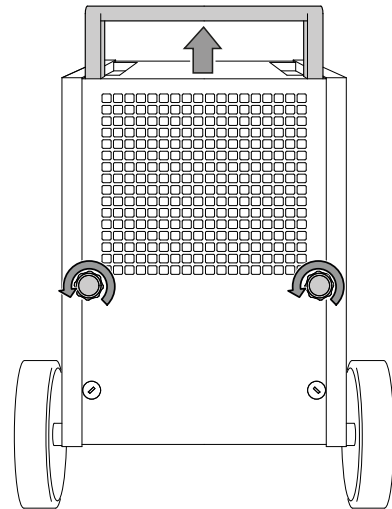

After transporting the device, observe the following:

- Set up the device in an upright position after transport.
- After having transported the device in horizontal position, leave the device to rest for 12 to 24 hours, so the refrigerant can accumulate within the compressor. Wait 12 to 24 hours before switching the device back on! Acting contrary might lead to compressor damage and a malfunctioning device. Any warranty claims will be voided in this case.

Storage

Before storing the device, observe the following:

- Drain the remaining condensate from the device and the condensation drain hose (see chapter Maintenance).
- Hold onto the mains plug while pulling the power cable out of the mains socket.
- Drain any possibly remaining condensate.

When the device is not being used, observe the following storage conditions:

- Only store the device in a room measuring more than 4 m².
- Only position the device in rooms where there is no source of ignition (e.g. open flames, an active gas appliance or an electric heater).
- dry and protected from frost and heat
- in an upright position where it is protected from dust and direct sunlight
- with a cover to protect it from invasive dust, if necessary
- Place no further devices or objects on top of the device to prevent it from being damaged.

Assembly and installation

Scope of delivery

- 1 x Device
- 1 x Air filter
- 1 x Condensation drain hose, 19 mm diameter
- 1 x Manual

Unpacking the device

1. Open the cardboard box and take the device out.
2. Completely remove the packaging.
3. Fully unwind the power cable. Make sure that the power cable is not damaged and that you do not damage it during unwinding.

Start-up

When positioning the device, observe the minimum distance from walls or other objects as described in the Technical data chapter.

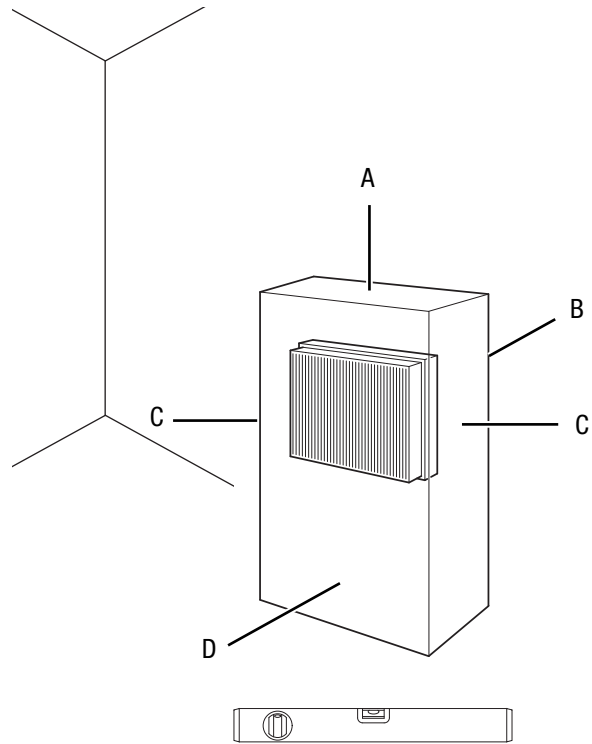

- Before restarting the device, check the condition of the power cable. If there are doubts as to the sound condition, contact the customer service.
- Only position the device in rooms where potentially leaking refrigerant cannot accumulate.
- Only position the device in rooms where there is no source of ignition (e.g. open flames, an active gas appliance or an electric heater).
- Set the device up in an upright and stable position.
- Do not create tripping hazards when laying the power cable or other electric cables, especially when positioning the device in the middle of the room. Use cable bridges.
- Make sure that extension cables are completely unrolled.
- When positioning the device, keep a sufficient distance to heat sources.
- Make sure that no curtains or other objects interfere with the air flow.
- When positioning the device, particularly in wet areas, secure it locally with an RCD (residual current device) which complies with the respective regulations.

Inserting the air filter

Note

Do not operate the device without an inserted air filter! Without the air filter, the inside of the device will be heavily contaminated. This could reduce the performance and result in damage to the device.

- Make sure that the air filter is installed before switching the device on.

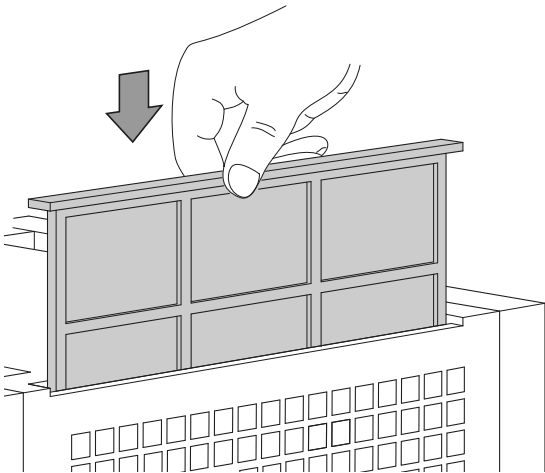

Inserting the condensation tank

- Ensure that the float inside the condensation tank is inserted correctly.
- Ensure that the condensation tank is empty and inserted correctly.

Installing the condensate pump (optional)



Info

If you use the device in combination with the condensate pump via the TTKwic port and with the Qube, the Qube should be switched on and ready for use at all times to ensure the continuous operation of the pump.

If the Qube's internal pump does not deliver, the collected condensate in the Qube can flow back from the container through the suction hoses.

1.

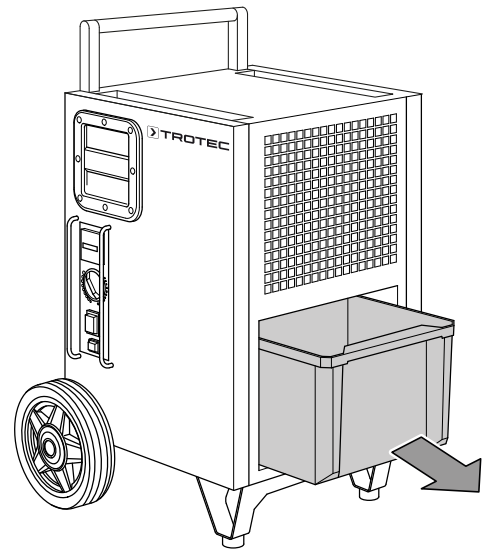

2.

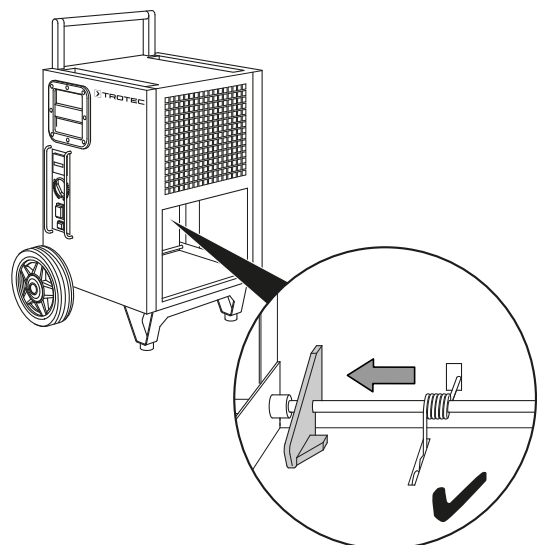
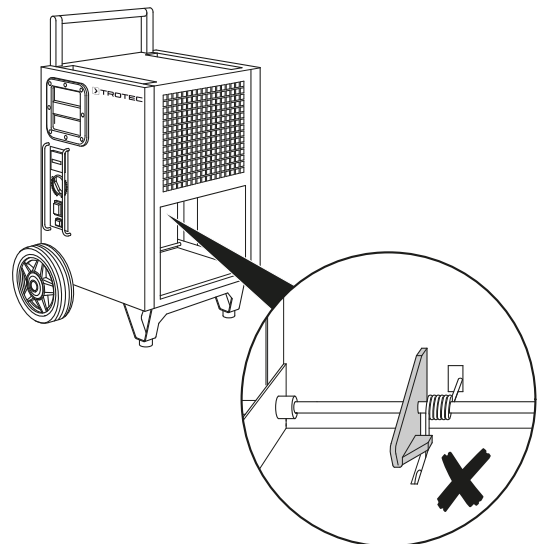

3.

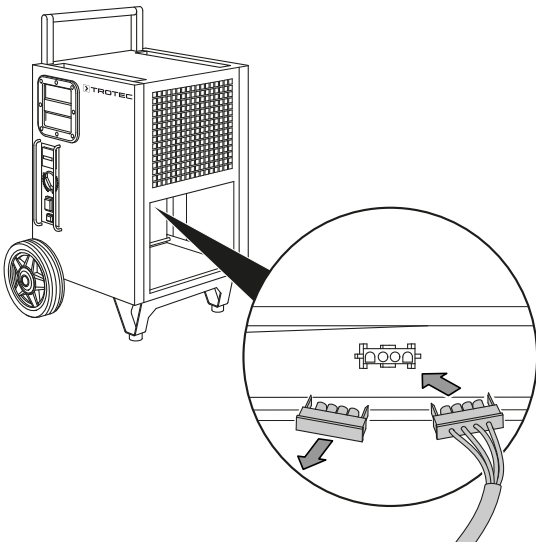

6.

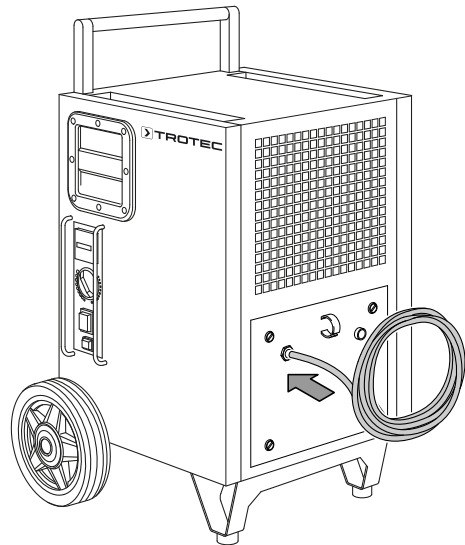

4.

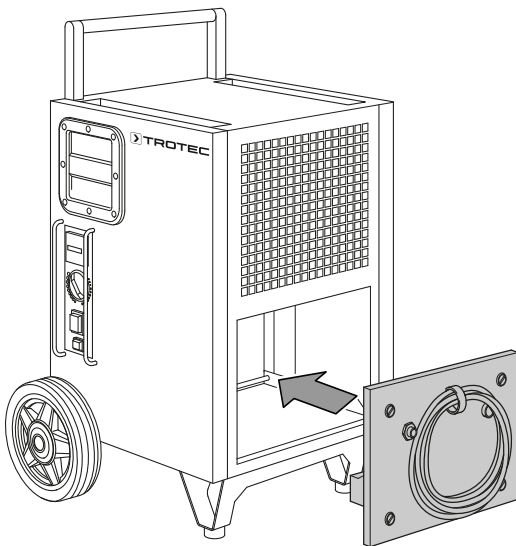

7.

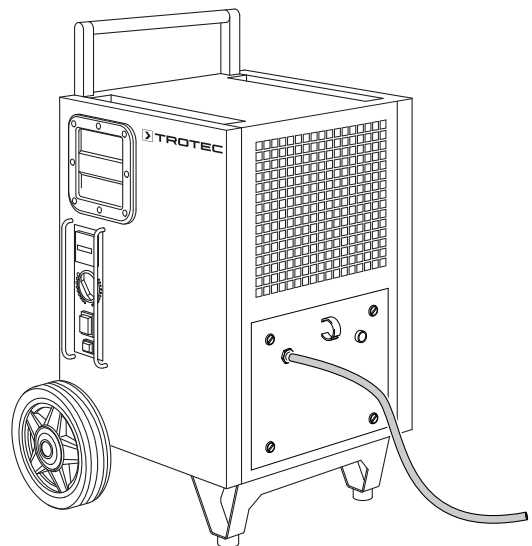

5.

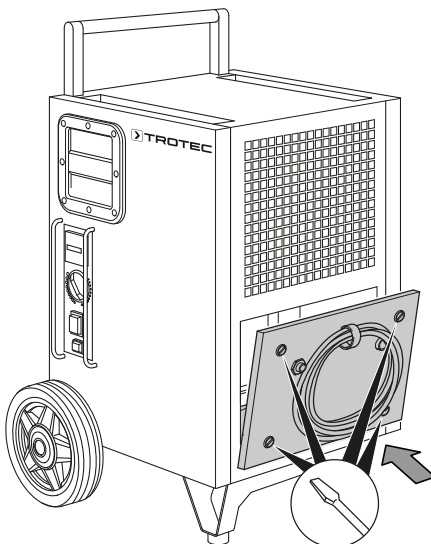

Connecting the power cable

- Insert the mains plug into a properly secured mains socket.

Operation

Operating element

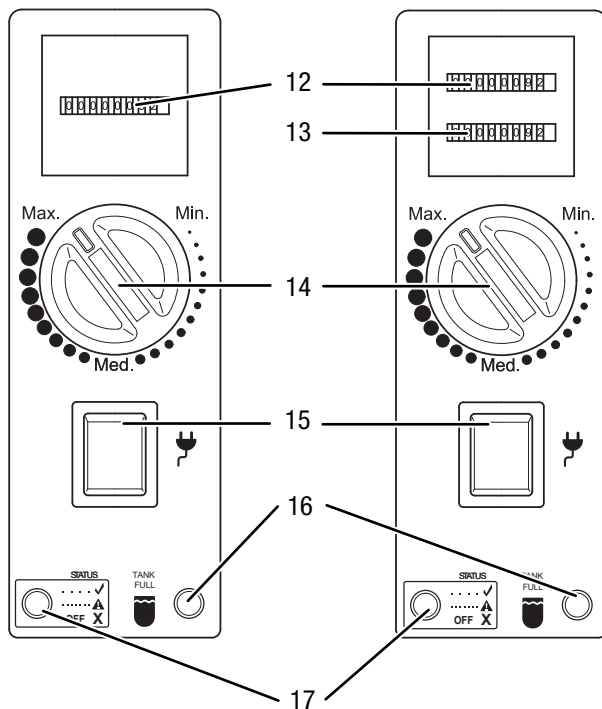

No.	Designation	Meaning
12	Operating hours counter	Indication of operating hours
13	Kilowatt hours counter, MID-certified (optional)	Indication of energy consumption
14	Rotary switch	Selection of relative room humidity
15	Mains switch	Switching the device on and off; Is illuminated when the device is switched on
16	Condensation tank LED	Is displayed when the condensation tank is full or not installed correctly
17	Status LED	Indicates the operating status and error messages

The device is optionally available with an operating element with dual counter (see the image at the top right). The dual counter registers both the operating hours and the energy consumption and is certified according to the MID (Measuring Instruments Directive 2004/22/EC). The kWh display is factory-calibrated and may be used for accounting purposes. Contact your Trotec customer service.

The *Status LED* (17) flashes once a second during normal operation. If it flashes more frequently, lights up permanently or does not light up at all, there might be a fault, see chapter Errors and faults.

Condensate pump (optional)

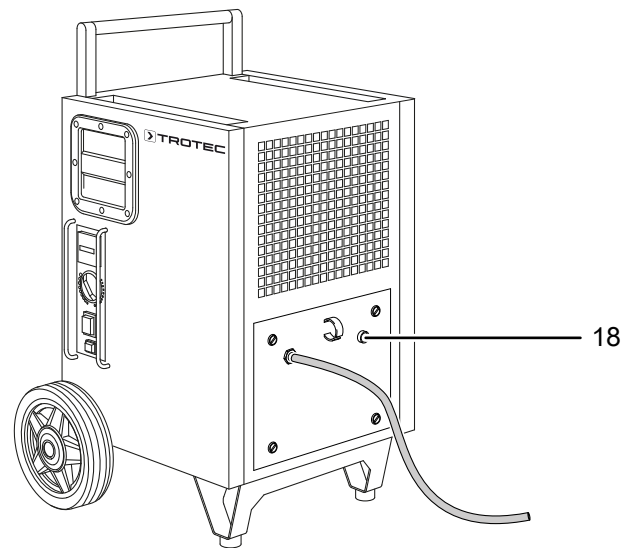

No.	Designation	Meaning
18	Condensate pump button	Switching the condensate pump on and off for draining residual water

The device can optionally be operated with a condensate pump (see chapter Installing the condensate pump (optional)). Contact your Trotec customer service.

Switching on and starting up the device

1. Ensure that the condensation drain hose is properly connected to the device and is free of damage.
2. Position a sufficiently large container (at least 20 litres; we recommend a 60-litre mortar tub) beside the device and insert the hose end. Check the filling level of the container regularly.
3. Make sure that the condensation drain hose is installed with a continuous decline.
4. Insert the mains plug into a properly secured mains socket.
5. Switch on the device at the mains switch (15).
6. Ensure that the mains switch (15) is lit.
7. Adjust the room humidity level with the rotary switch (14).

Continuous operation mode

In continuous operation mode, the device dehumidifies the air constantly, regardless of the humidity. To start continuous operation mode, set the rotary switch (14) to Max.

Operation with hose attached to the condensation connection

For continuous operation or unattended dehumidification, please connect the supplied condensation drain hose to the device.

- ✓ A suitable hose (diameter: 19 mm) is ready for use.
- ✓ The device is switched off.

1. Remove the condensation tank.

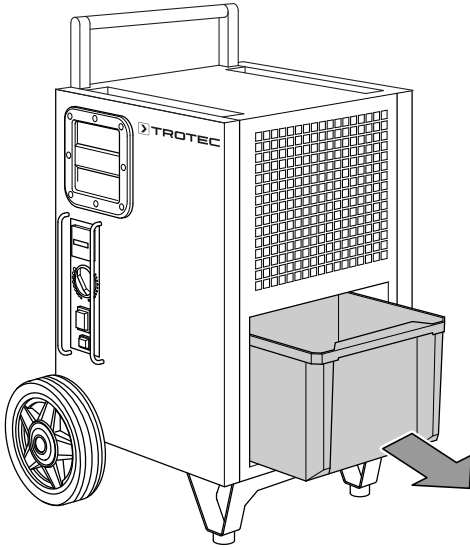

2. Push the spring back as illustrated.

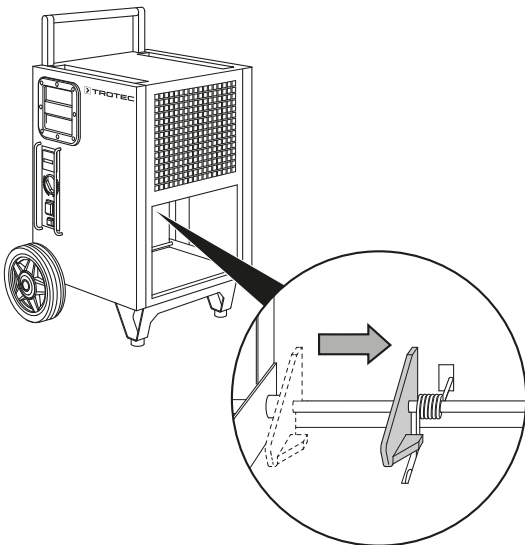

3. Check whether the hose is properly positioned on the connection. Screw it on to the device connection as illustrated.

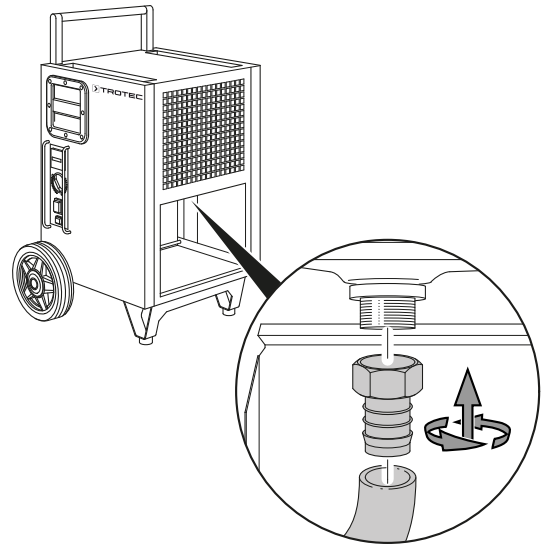

4. Guide the other hose end to a suitable drain or sufficiently dimensioned collection container. Please note that the hose must not be kinked.

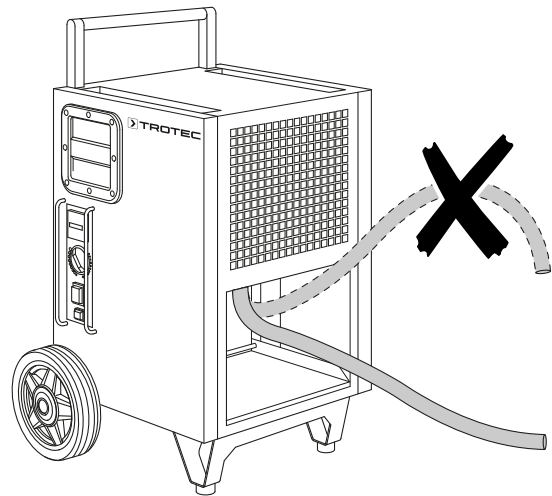

Remove the hose if you want to collect the condensate in the condensation tank again. Allow the hose to dry prior to storage. The hose can be connected in any operating mode for continuous operation.

Automatic defrost

If the room temperature is below 11 °C, the evaporator will freeze during dehumidification. The device will then carry out an automatic defrost. The duration of the defrost process can vary.

- Do not switch off the device during automatic defrost. Do not remove the mains plug from the mains socket.

Temperature limitation (overheating protection)

The device comes with a temperature limitation. It serves to protect e.g. the compressor from overheating.

- Upper temperature limit: +35 °C +/- 2 °C
- Lower temperature limit: -3 °C +/- 2 °C

If the ambient temperature exceeds or falls below these limits, the device automatically switches off the compressor; only the fan will keep running. This feature protects the device from overloading since high temperatures and high humidity levels expose the device to extreme stresses. Moreover, drying is no longer economical at such high temperatures and also poses dangers for the inventory of the room to be dried. Please note that the switch-off function works with a switch-on hysteresis of -2 °C.



Info

The compressor always starts with a delay. This protects the compressor and thus increases its lifetime. If you remove the condensation tank from the device and reinsert it after emptying, the compressor will switch back on with a delay of approx. 3 min. This delay is also enabled in optional hygrostat operation. If the room humidity exceeds the setting of the selection switch, the compressor will only switch back on after a delay.

The fan keeps running independently of the compressor. The fan only switches off if the condensation tank is removed.

Shutdown



Warning of electrical voltage

Do not touch the mains plug with wet or damp hands.

- Switch off the device.
- Hold onto the mains plug while pulling the power cable out of the mains socket.
- Empty the condensation tank, if need be.
- Clean the device according to the Maintenance chapter.
- Store the device according to the Storage chapter.

Available accessories



Warning

Only use accessories and additional equipment specified in the instructions.

Using insertion tools or accessories other than those specified in the instructions may cause a risk of injury.

Designation	Article number
Air filter TTK 175 S	7.160.000.007
Air filter TTK 355 S	7.160.000.008
External condensate pump	6,100,003,030
Protective cover TTK 175 S	6.100.003.105
Protective cover TTK 355 S	6.100.003.110

Errors and faults

The device has been checked for proper functioning several times during production. If malfunctions occur nonetheless, check the device according to the following list.

The device does not start:

- Check the power connection.
- Check the power cable and mains plug for damage.
- Check the on-site fusing.
- Check the filling level of the condensation tank and empty it if necessary. The *Condensation tank* LED (16) must not light up.
- Check the condensation tank for correct seating.
- Check the room temperature. Observe the device's permissible operating range according to the technical data.
- Check the float in the condensation tank for dirt. If necessary, clean the condensation tank. The float must be able to move freely.

The device is running, but there is no formation of condensate:

- Check the float in the condensation tank for dirt. If necessary, clean the condensation tank. The float must be able to move freely.
- Check the room temperature. Observe the device's permissible operating range according to the technical data.
- Ensure that the relative room humidity complies with the technical data.
- Check the air filter for dirt. If necessary, clean or replace the air filter.
- From the outside, check the condenser for dirt (see chapter Maintenance). If the condenser is dirty, have it cleaned by a specialist company or by Trotec.
- The device might carry out an automatic defrost. During automatic defrost, the device does not dehumidify.

The device is loud or vibrates:

- Check whether the device is set up in a stable and upright position.

Condensate is leaking:

- Check the device for leaks.

The compressor does not start:

- Check the room temperature. Observe the device's permissible operating range according to the technical data.
- Check whether the overheating protection of the compressor has tripped. Disconnect the device from the mains and let it cool down for approx. 10 minutes before reconnecting it.

- The device might carry out an automatic defrost. During automatic defrost, the device does not dehumidify.

The device gets very warm, is loud or loses power:

- Check the air inlets and air filters for dirt. Remove external dirt.
- From the outside, check the device for dirt (see chapter Maintenance). If the inside of the device is dirty, have it cleaned by a specialist company for cooling and air-conditioning or by Trotec.

Your device still does not operate correctly after these checks?

Please contact the customer service. If necessary, bring the device to a specialist company for cooling and air-conditioning or to Trotec for repair.

Error codes

The *Status* LED (17) can indicate the following statuses during operation:

Error message	Meaning	Remedy
Flashing once per second	Normal operation	No remedy required
Flashing five times per second	The temperature is above or below the limit.	The temperature should be within the operating temperature range specified in the Technical data.
	The humidity level has reached the switching point.	The device will switch back on once the humidity level set is exceeded.
Permanently illuminated	There is a general problem.	Please contact the customer service.
Not illuminated		

Maintenance

Maintenance intervals

Maintenance and care interval	before every start-up	as needed	at least every 2 weeks	at least every 4 weeks	at least every 6 months	at least annually
Check the air inlets and outlets for dirt and foreign objects and clean if necessary	X			X		
Clean the exterior		X				X
Visually check the inside of the device for dirt		X				X
Check the air filter for dirt and foreign objects and clean or replace if necessary	X		X			
Replace the air filter					X	
Check for damage	X					
Check the attachment screws		X				X
Test run						X
Empty the condensation tank and/or drain hose		X				

Maintenance and care log

Device type:

Device number:

Maintenance and care interval	1	2	3	4	5	6	7	8	9	10	11	12	13	14	15	16
Check air inlets and outlets for dirt and foreign objects and clean if necessary																
Clean the exterior																
Visually check the inside of the device for dirt																
Check the air filter for dirt and foreign objects and clean or replace if necessary																
Replace the air filter																
Check for damage																
Check the attachment screws																
Test run																
Empty the condensation tank and/or drain hose																
Comments																

1. Date: Signature:	2. Date: Signature:	3. Date: Signature:	4. Date: Signature:
5. Date: Signature:	6. Date: Signature:	7. Date: Signature:	8. Date: Signature:
9. Date: Signature:	10. Date: Signature:	11. Date: Signature:	12. Date: Signature:
13. Date: Signature:	14. Date: Signature:	15. Date: Signature:	16. Date: Signature:

Activities required before starting maintenance



Warning of electrical voltage

Do not touch the mains plug with wet or damp hands.

- Switch the device off.
- Hold onto the mains plug while pulling the power cable out of the mains socket.



Warning of electrical voltage

Tasks which require the housing to be opened must only be carried out by authorised specialist companies or by Trotec.

Running capacitor

Note

Replace the running capacitor after 10,000 operating hours!

Refrigerant circuit



Danger

Natural refrigerant propane (R290)!

H220 – Extremely flammable gas.
 H280 – Contains gas under pressure; may explode if heated.

P210 – Keep away from heat, sparks, open flames and other ignition sources. No smoking.
 P377 – Leaking gas fire: Do not extinguish, unless leak can be stopped safely.
 P410+P403 – Protect from sunlight. Store in a well-ventilated place.



Danger

Refrigerant R454C!

H220 – Extremely flammable gas.
 H280 – Contains gas under pressure; may explode if heated.

P210 – Keep away from heat, sparks, open flames and other ignition sources. No smoking.
 P381 – Eliminate all ignition sources if safe to do so.
 P403 – Store in a well-ventilated place.

- The entire refrigerant circuit is a maintenance-free, hermetically sealed system and may only be maintained or repaired by specialist companies for cooling and air-conditioning or by Trotec.

Safety signs and labels on the device

Check the safety signs and labels attached to the device at regular intervals. Replace illegible safety signs!

Cleaning the housing

Clean the housing with a soft, damp and lint-free cloth. Ensure that no moisture enters the housing. Protect electrical components from moisture. Do not use any aggressive cleaning agents such as cleaning sprays, solvents, alcohol-based or abrasive cleaners to dampen the cloth.

Visual inspection of the inside of the device for dirt

1. Remove the air filter.
2. Use a torch to illuminate the openings of the device.
3. Check the inside of the device for dirt.
4. If you see a thick layer of dust, have the inside of the device cleaned by a specialist company for cooling and air-conditioning or by Trotec.
5. Put the air filter back in.

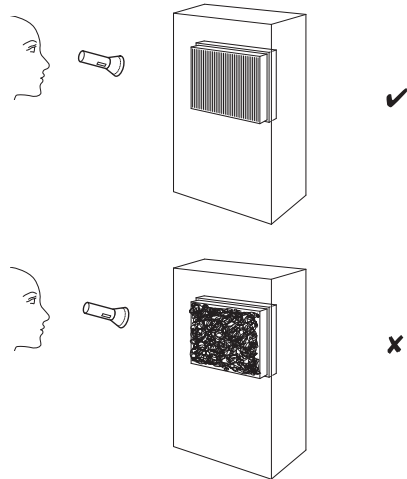

Cleaning the air filter

Note

Ensure that the air filter is not worn or damaged. The corners and edges of the air filter must not be deformed or rounded. Before reinserting the air filter, make sure that it is undamaged and dry!

The air filter has to be cleaned as soon as it is dirty. This is brought to light e.g. by a reduced capacity (see chapter Errors and faults).

1. Remove the air filter from the device.

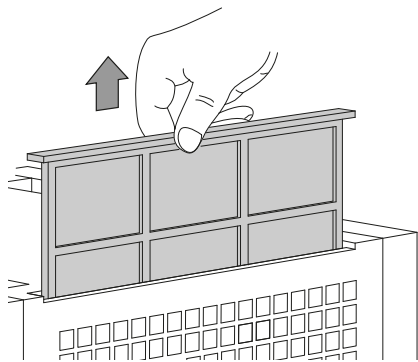

2. Clean the filter using a slightly damp, soft, lint-free cloth. If the filter is heavily contaminated, clean it with warm water mixed with a neutral cleaning agent.

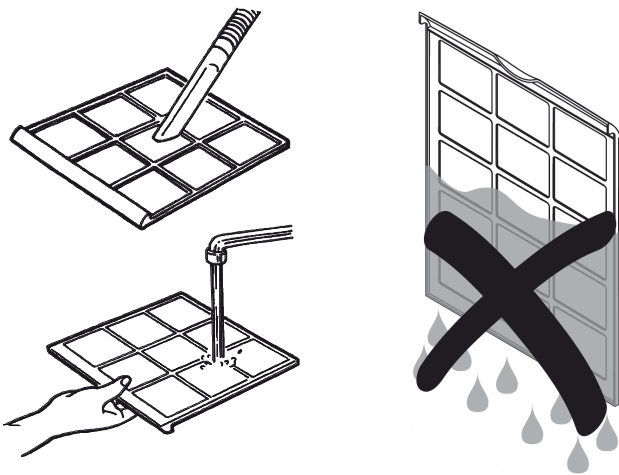

3. Allow the filter to dry completely. Do not insert a wet filter into the device!
4. Reinsert the air filter into the device.

Emptying the condensation tank



Info

The compressor always starts with a delay. This protects the compressor and thus increases its lifetime. If you remove the condensation tank from the device and reinsert it after emptying, the compressor will switch back on with a delay of approx. 3 min. This delay is also enabled in optional hygrostat operation. If the room humidity exceeds the setting of the selection switch, the compressor will only switch back on after a delay.

The fan keeps running independently of the compressor. The fan only switches off if the condensation tank is removed.

- 1.

TANK FULL

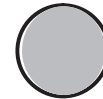

- 2.

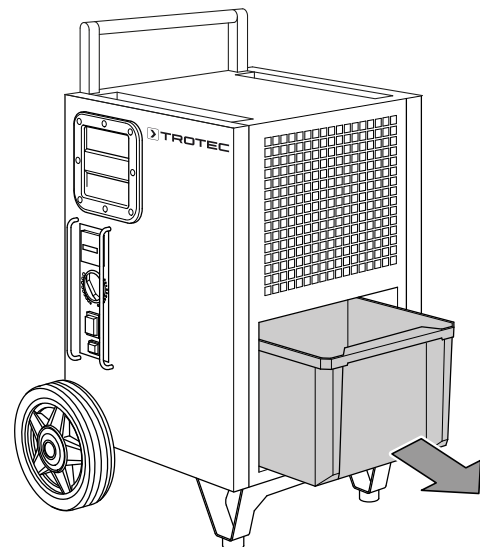

3.

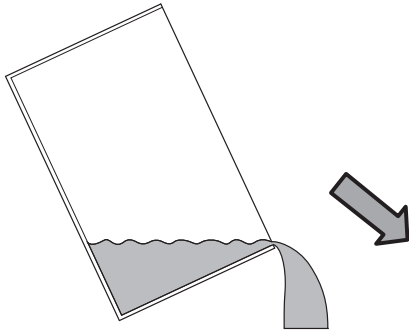

4.

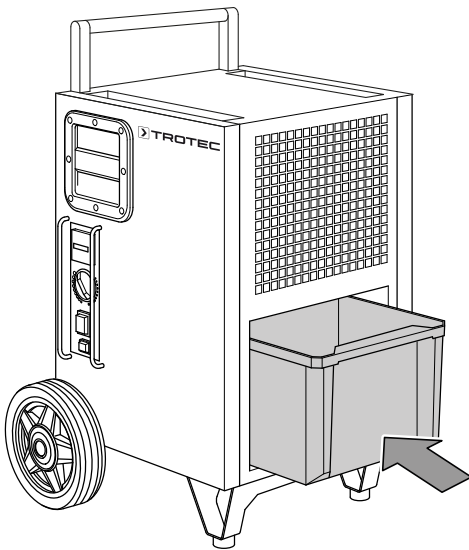

If the condensation tank is full or not installed correctly, the *Condensation tank* LED (16) will be illuminated. The compressor and fan will switch off.

Activities required after maintenance

If you want to continue using the device:

- Reconnect the device to the mains.

If you do not intend to use the device for a considerable time:

- Store the device according to the Storage chapter.

Technical annex
Technical data

Parameter	Value		
	TTK 175 S	TTK 175 S	TTK 355 S
Model	TTK 175 S	TTK 175 S	TTK 355 S
Article number	1.120.000.157	1.120.000.159	1.120.000.163
Dehumidification performance @ 30 °C / 80 % RH	40 l / 24 h	40 l / 24 h	55 l / 24 h
Dehumidification performance, max.	50 l / 24 h	50 l / 24 h	70 l / 24 h
Operating range (temperature)	5–32 °C	5–32 °C	5–32 °C
Operating range (relative humidity)	50 % – 90 % RH	50 % – 90 % RH	50 % – 90 % RH
Max. permissible pressure	3.1 MPa	3.1 MPa	1.8 MPa
Pressure suction side	1.1 MPa	1.1 MPa	0.5 MPa
Pressure outlet side	3.1 MPa	3.1 MPa	1.8 MPa
Air volume flow	580 m ³ /h	580 m ³ /h	1,000 m ³ /h
Mains connection	220-240 V / 50 Hz	110 / 230 V ~ 50 Hz	220-240 V / 50 Hz
Power consumption, max.	0.6 kW	0.6 kW	1.3 kW
Nominal current	2.8 A	5.7 / 2.7 A	6 A
Water tank capacity	6 l	6 l	6 l
Refrigerant	R290 (propane)	R290 (propane)	R454C (F-Gas)
Amount of refrigerant	150 g	150 g	650 g
GWP factor	3	3	146
CO ₂ equivalent	0.00045 t	0.00045 t	0.09490 t
Sound pressure level LpA (1 m; complies with DIN 45635-01-KL3)	52 dB(A)	52 dB(A)	54 dB(A)
Dimensions (length x width x height)	390 x 380 x 643 mm	390 x 380 x 643 mm	390 x 380 x 725 mm
Minimum distance to walls or other objects	top (A): 50 cm rear (B): 50 cm sides (C): 50 cm front (D): 50 cm	50 cm 50 cm 50 cm 50 cm	50 cm 50 cm 50 cm 50 cm
Weight	35 kg	39 kg	39 kg

Wiring diagram

With operating hours counter

Wiring diagram with tank present & full tank & condensates pump resetting the PCB
Hour counter just counting the compressor operation time

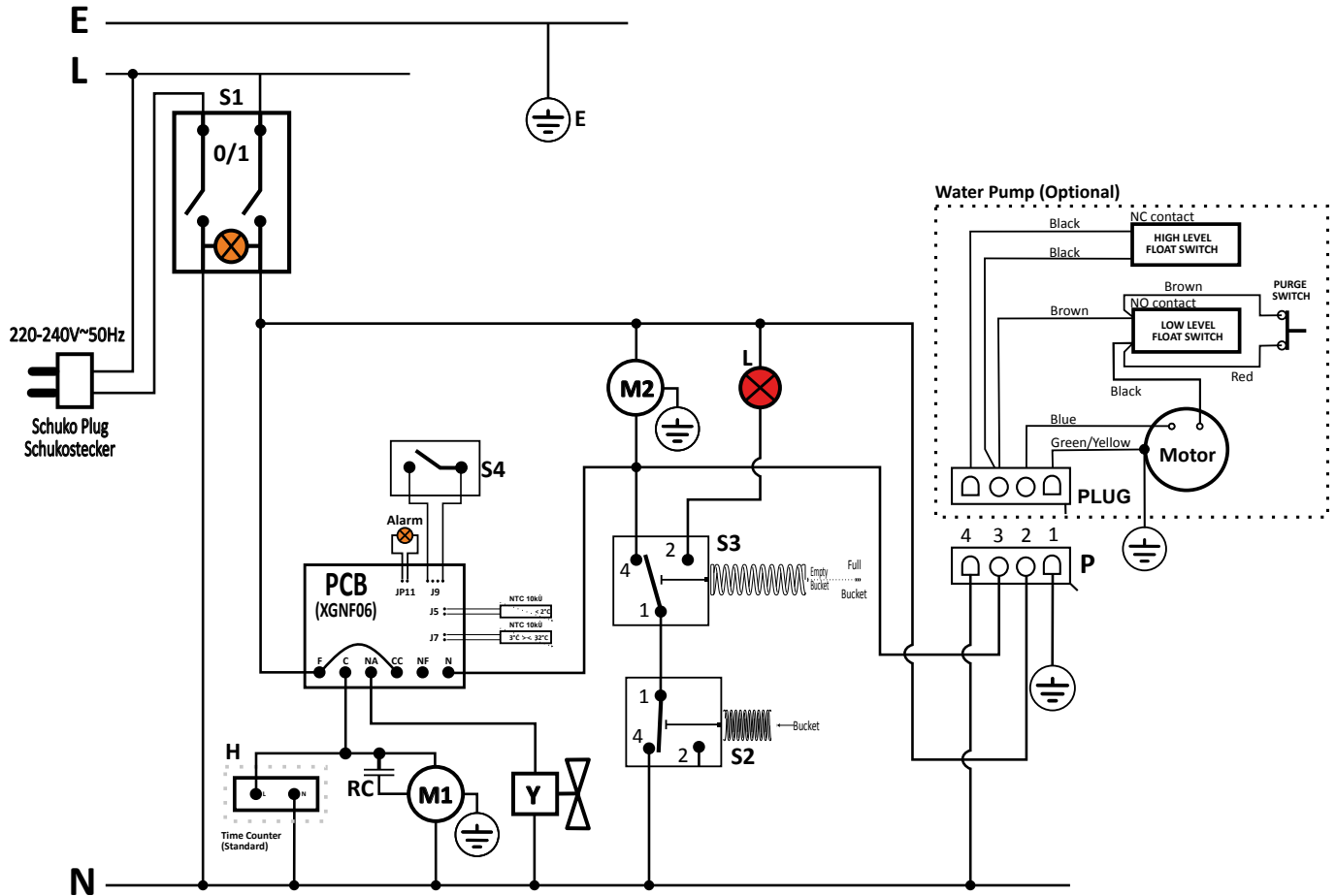

- E - Earthing / Erdung
- N - Common Line / Gemeinsame
- L - Line / Außenleiter
- S1 - On-Off Switch / Geräteschalter 0/1
- S2 - Micro switch (Tank Presence) / Mikroschalter Wippe Vollstand (Tank Präsenz)
- S3 - Micro Switch (Tank Full) / Mikroschalter Wippe Vollstand (Behälter voll)
- S4 - Humidistat / Hygrostat
- L - Red lamp (Tank full) / Signalleuchte " rot " (Behälter voll)
- M1 - Compressor / Kompressor
- M2 - Fan motor / Lüftermotor
- Y - Two Way Valve / Abtau-Magnetventil
- RC - Running Capacitor / Motorbetriebskondensator
- H - Time Counter (Standard) / Zeit Zähler (Standard)
- P - Water Pump Socket / Wasserpumpe Stockdose

With operating hours counter and MID counter

Wiring diagram with tank present & full tank & condensates pump resetting the PCB
Counter counting energy and time downstream the main switch

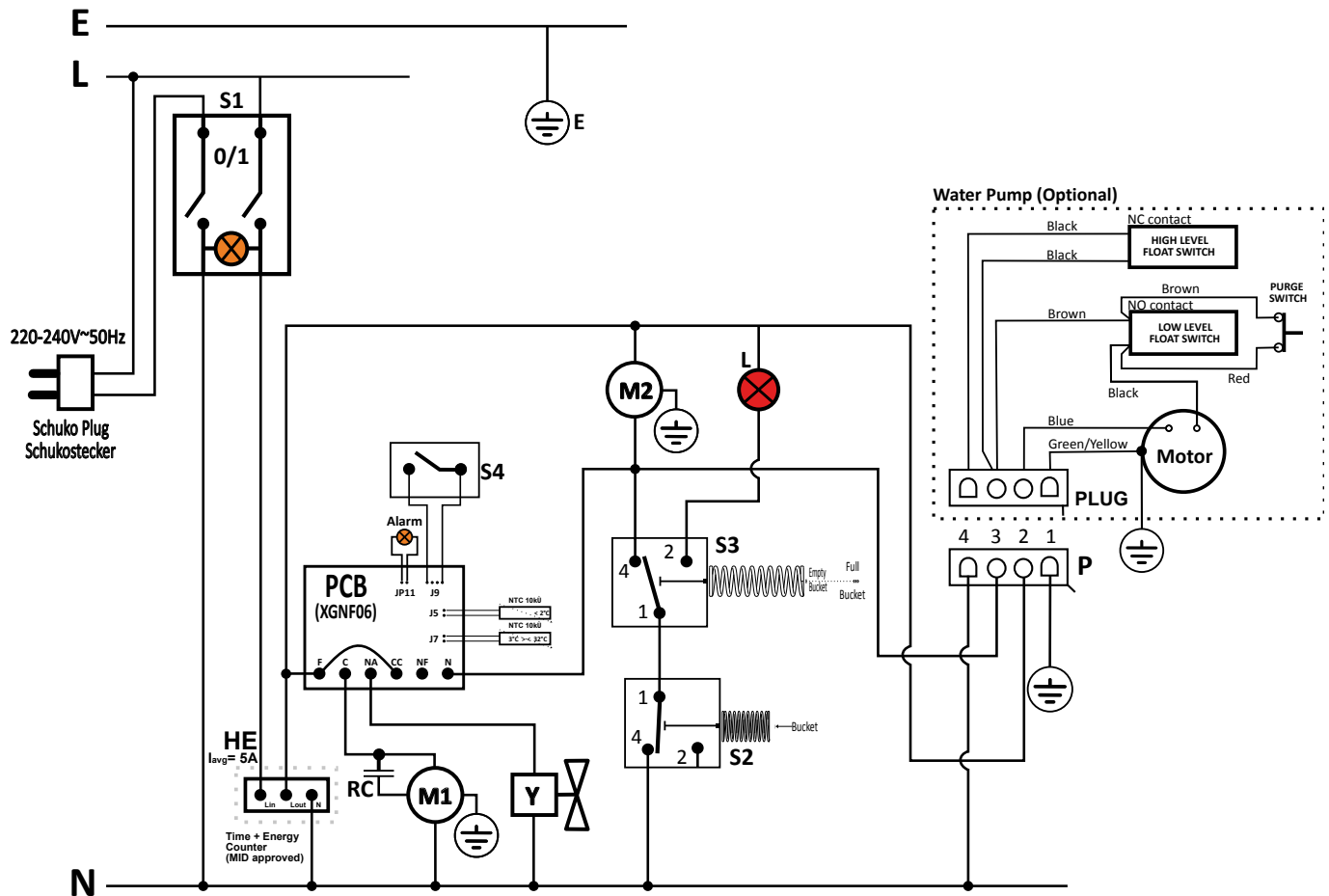

- E - Earthing / Erdung
- N - Common Line / Gemeinsame
- L - Line / Außenleiter
- S1 - On-Off Switch / Geräteschalter 0/1
- S2 - Micro switch (Tank Presence) / Mikroschalter Wippe Vollstand (Tank Präsenz)
- S3 - Micro Switch (Tank Full) / Mikroschalter Wippe Vollstand (Behälter voll)
- S4 - Humidistat / Hygrostat
- L - Red lamp (Tank Presence) / Signalleuchte " rot " (Tank Präsenz)
- M1 - Compressor / Kompressor
- M2 - Fan motor / Lüftermotor
- Y - Two Way Valve / Abtau-Magnetventil
- RC - Running Capacitor / Motorbetriebskondensator
- HE - Time + Energy Counter (Optional) / Zeit + Energie Zähler (Zusätzliche)
- P - Water Pump Socket / Wasserpumpe Stockdose

Exploded assembly drawing



Info

The position numbers of the spare parts differ from those describing the positions of the components mentioned in these instructions.

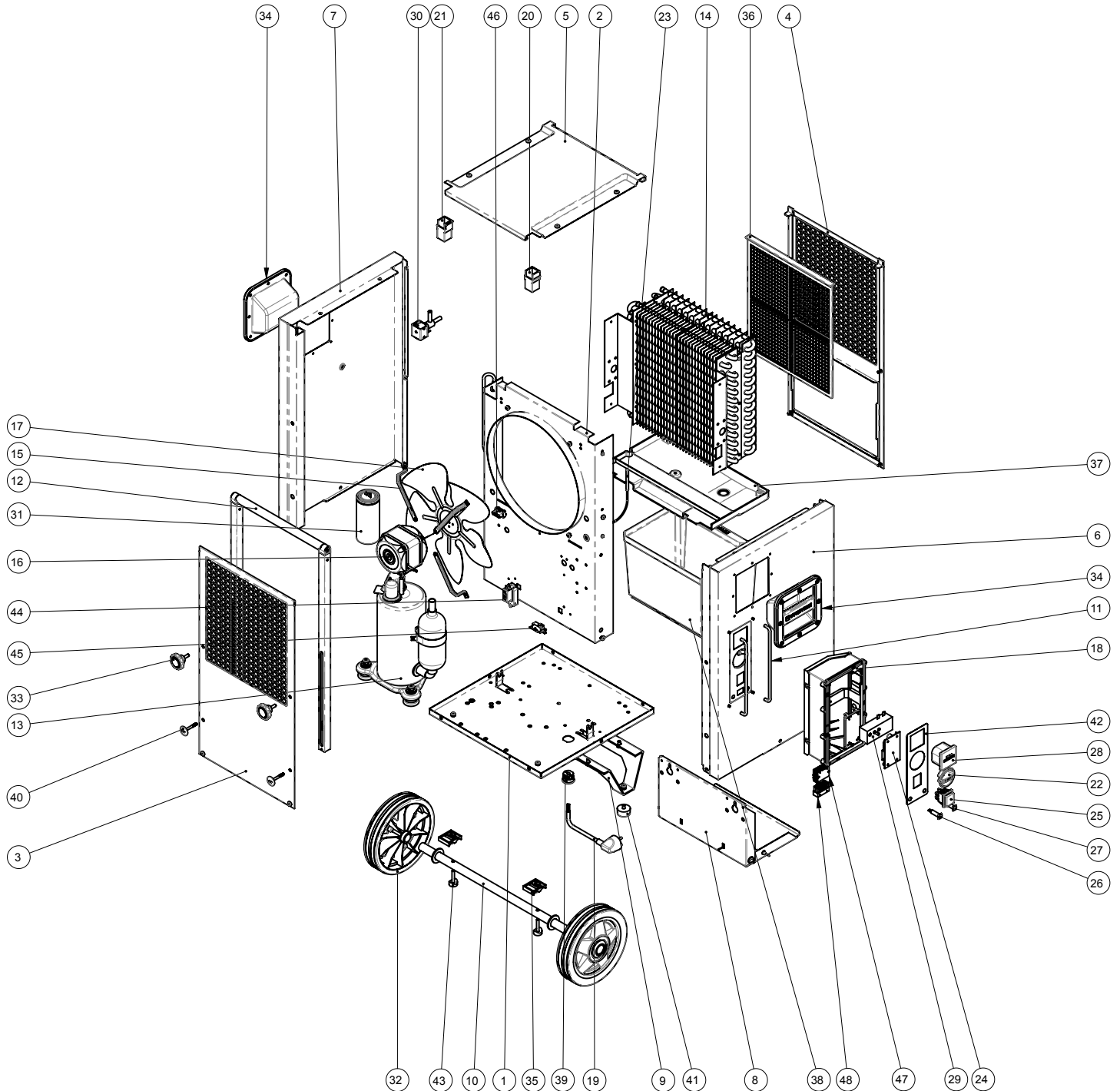

List of spare parts

No.	Spare part	No.	Spare part	No.	Spare part
1	Baseplate	17	Fan blade	33	Star type knob
2	Main frame	18	Control's box	34	Plastic Handle
3	Air inlet grille	19	Power supply cable	35	Axle's saddle
4	Air outlet grille	20	Right tubular sliding guide	36	Dust Filter
5	Top panel	21	Left tubular sliding guide	37	Condensates water pan
6	Control's side panel	22	Humidistat knob	38	Water Tank
7	Left panel	23	Defrost sensor	39	Cable gland
8	Water tank baseplate (complete set)	24	Electronic controller	40	Handle security pin
9	Structural foot	25	Main switch	41	Rubber feet
10	Wheel's axle	26	Electronic controller status LED	42	Control panel sticker
11	Control's protection bars	27	Tank full alarm lamp	43	Axle's saddle spacer
12	Handle	28	Time counter	44	Mechanical switch set
13	Compressor	29	Hygostat	45	Microswitch
14	Heat exchanger	30	Defrost valve coil	46	Condensates pump socket
15	Fan motor brackets	31	Running capacitor	47	Control's box internal wiring
16	Fan motor	32	Wheel	48	Unit's internal wiring

Disposal



The icon with the crossed-out waste bin on waste electrical or electronic equipment stipulates that this equipment must not be disposed of with the household waste at the end of its life. You will find collection points for free return of waste electrical and electronic equipment in your vicinity. The addresses can be obtained from your municipality or local administration. For further return options provided by us please refer to our website <https://de.trotec.com/shop/>.

The separate collection of waste electrical and electronic equipment aims to enable the re-use, recycling and other forms of recovery of waste equipment as well as to prevent negative effects for the environment and human health caused by the disposal of hazardous substances potentially contained in the equipment.

The device is operated with fluorinated greenhouse gas which can be dangerous for the environment and contribute to global warming when emitted to the atmosphere.

Further information is provided on the nameplate.

Dispose of the refrigerant appropriately and according to the national regulations.

Have the refrigerant (propane) disposed of appropriately and according to the national regulations by a company with the relevant certification (European Waste Catalogue 160504).

Declaration of conformity

The text below sets out the contents of the declaration of conformity. The signed declaration of conformity can be found at <https://hub.trotec.com/?id=39717>.

Declaration of conformity

in accordance with the EC Machinery Directive 2006/42/EC, Annex II, Part 1, Section A

Herewith, we – Trotec GmbH– declare that the machinery designated below was developed, constructed and produced in compliance with the requirements of the EC Machinery Directive in the version 2006/42/EC.

Product model / product: TTK 175 S / TTK 355 S

Product type: dehumidifier

Year of manufacture as of: 2.020

Relevant EU directives:

- 2011/65/EU: 01/07/2011
- 2014/30/EU: 29/03/2014
- 2012/19/EU: 24/07/2012
- 2015/863/EU

Applied harmonised standards:

- EN 60335-1:2012
- EN 60335-1:2012/AC:2014
- EN 60335-1:2012/A11:2014
- EN 60335-1:2012/A13:2017
- EN 60335-2-40:2003
- EN 60335-2-40:2003/A11:2004
- EN 60335-2-40:2003/A12:2005
- EN 60335-2-40:2003/A1:2006
- EN 60335-2-40:2003/AC:2006
- EN 60335-2-40:2003/A2:2009
- EN 60335-2-40:2003/AC:2010
- EN 60335-2-40:2003/A13:2012
- EN 60335-2-40:2003/A13:2012/AC:2013
- EN 61000-3-2:2014
- EN 61000-3-3:2013

Applied national standards and technical specifications:

- IEC 60335-1:2010
- IEC 60335-1:2010/AMD1:2013
- IEC 60335-1:2010/AMD2:2016
- IEC 60335-2-40:2018
- IEC 61000-3-2:2018
- IEC 61000-3-3:2013
- IEC 61000-3-3:2013/AMD:2017
- EN 55014-1:2017
- CISPR 14-1:2016
- EN 55014-2:2015
- CISPR 14-2:2015

Manufacturer and name of the authorised representative of the technical documentation:

Trotec GmbH
Grebener Straße 7, D-52525 Heinsberg
Phone: +49 2452 962-400
E-mail: info@trotec.de

Place and date of issue:
Heinsberg, 05/03/2020

Detlef von der Lieck, Managing Director

Trotec GmbH

Grebener Str. 7
D-52525 Heinsberg

☎ +49 2452 962-400

☎ +49 2452 962-200

✉ info@trotec.com

www.trotec.com